

ALTRU...V

ALTRU-V (A Division of UVDI)
26145 Technology Drive
Valencia, CA 91355
Tel 877-PUREUVC (877-787-3882)
Tel 661-295-8140
Fax 661-257-4698
www.altruv.com

REPRESENTED BY:

The **V-Strike IDM** can be installed easily onto almost all manufacturer's coil boxes or ductwork in either vertical, horizontal or counter-flow applications. It is installed from outside so there is no need to open or compromise the equipment. The installation is as simple as making two holes for the lamps, screwing the **V-Strike IDM** onto the plenum duct and just plug it in!

The lamps can be safely replaced in minutes using the exclusive quarter-turn lamp lock-in devices.

Independent Testing: ALTRU-V systems have been independently tested to verify conformance to UL/C-UL per Category Code ABQK (Accessories, Air Duct Mounted) and UL Standards: 153, 1598 & 1995 respectively.

The health aspects associated with the use of this product and its ability to aid in the disinfection of environmental air have not been investigated by UL.

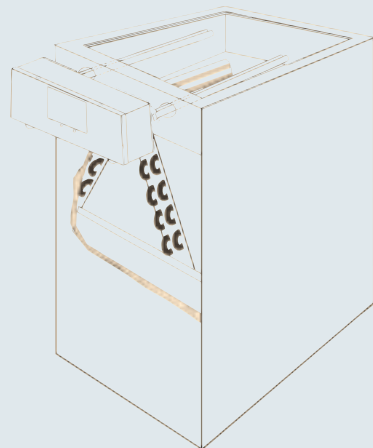
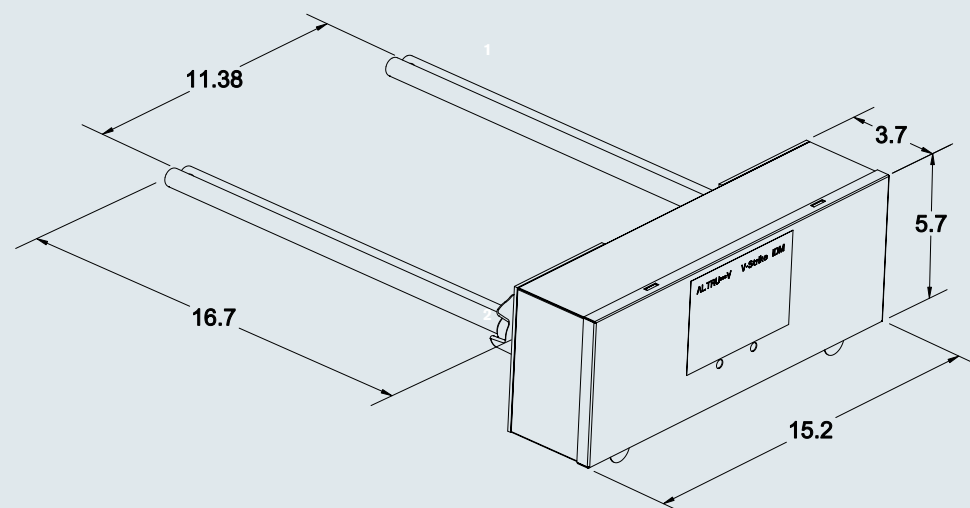

Typical "A" Coil

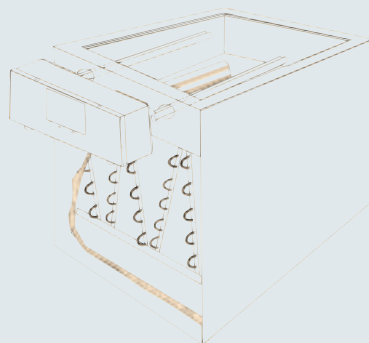

Typical Wedge Coil

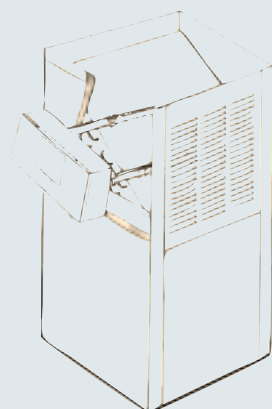

Typical Slab Coil

Model No.	Description	Nom. Dim.	Electrical	Weight	Part Number
VS-IDM	Dual Lamp UVC Module		120Vac, 60 Hz, 36 Watts	6 Lbs.	20-1000
IDM-15-PLL	Dual Lamp Replacement Pack (2 ea.)	18"	-	2 Lbs.	20-5000

A DIVISION OF UVDI

REAL SCIENCE FOR HVAC MAINTENANCE

ALTRU...V

V-STRIKE IDM™ EXTERNAL SYSTEM-MOUNT DUAL "BI-AXIAL" ULTRAVIOLET LAMP MODULE

Use the **V-Strike IDM** to improve indoor air quality by destroying A/C surface and airborne microbes where they grow and circulate – for a cleaner system and occupied space.

VALUABLE BENEFITS FROM THE LEADER IN THE APPLICATION OF UV

IDM Performance & Safety

- Extended dual bi-axial lamp fixture design provides superior coverage, output and performance
- The most environmentally friendly lamps from the largest lamp manufacturer in the world
- Longer lasting lamps that provide over 9000 hours of use (about one year when used full time)
- Fixture includes LED indicators that demonstrate lamp and power supply functionality
- Built-in safety features are provided to prevent accidental exposure to UV and electrical shock
- Can pay for itself through maintenance and energy savings, often in less than one year
- One-year warranty on the fixture as well as the lamps

IDM Personal Benefits

- Helps to reduce infectious disease microorganisms including colds, flu, etc.
- Helps to destroy A/C surface mold and their by-products – allergy, odor and upper respiratory offenders
- V-Strike IDM lamps do not produce ozone or other contaminants

IDM Installation & Features

- Installs quickly, easily and safely into light commercial systems
- Convenient size allows installation onto commercial air systems and ductwork of systems up to 8 tons
- Easy lamp change-out in less than ten minutes using IDM's exclusive quarter turn lamp lock-in devices
- Fixtures are listed as UL/C-UL under Category Code ABQK, three UL Standards of product safety.

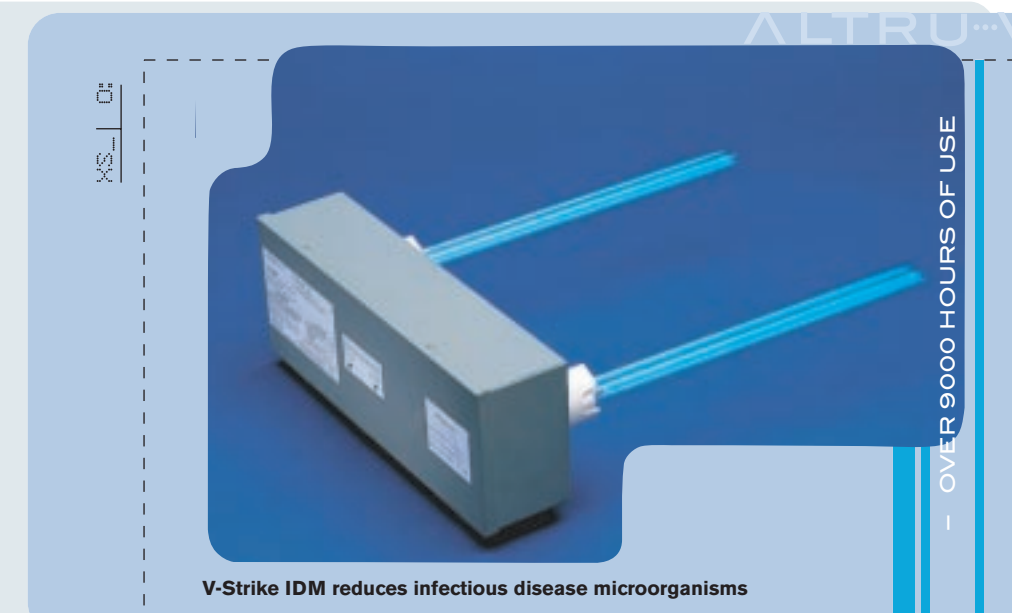

EQUATES TO CLEANER INDOOR AIR

Dark and often damp Heating, Ventilating and Air Conditioning (HVAC) systems are not only a proven breeding ground for certain mold and some bacterial contaminants, they are the perfect means by which to distribute them. They also circulate other microorganisms such as human and animal sourced bacteria and viruses throughout the occupied space.

According to EPA sponsored studies, indoor levels of pollutants can be much higher than outdoor levels. Many of these pollutants are "bioaerosols", indoor air contaminants that can do the most harm, according to the World Health Organization (WHO). These contaminants should be of particular concern because we spend about 90% of our time in these spaces.

Research has shown that building occupants exposed to such contaminants can develop allergic reactions, resulting in sinus congestion, headaches and triggered asthma attacks – along with germ related ailments that include colds and flu.

The V-Strike IDM can assist in the destruction of these contaminants, helping to protect building occupants.



V-STRIKE IDM